

Typ
Type

145/40-779C

(Art.-Nr. 12000639)

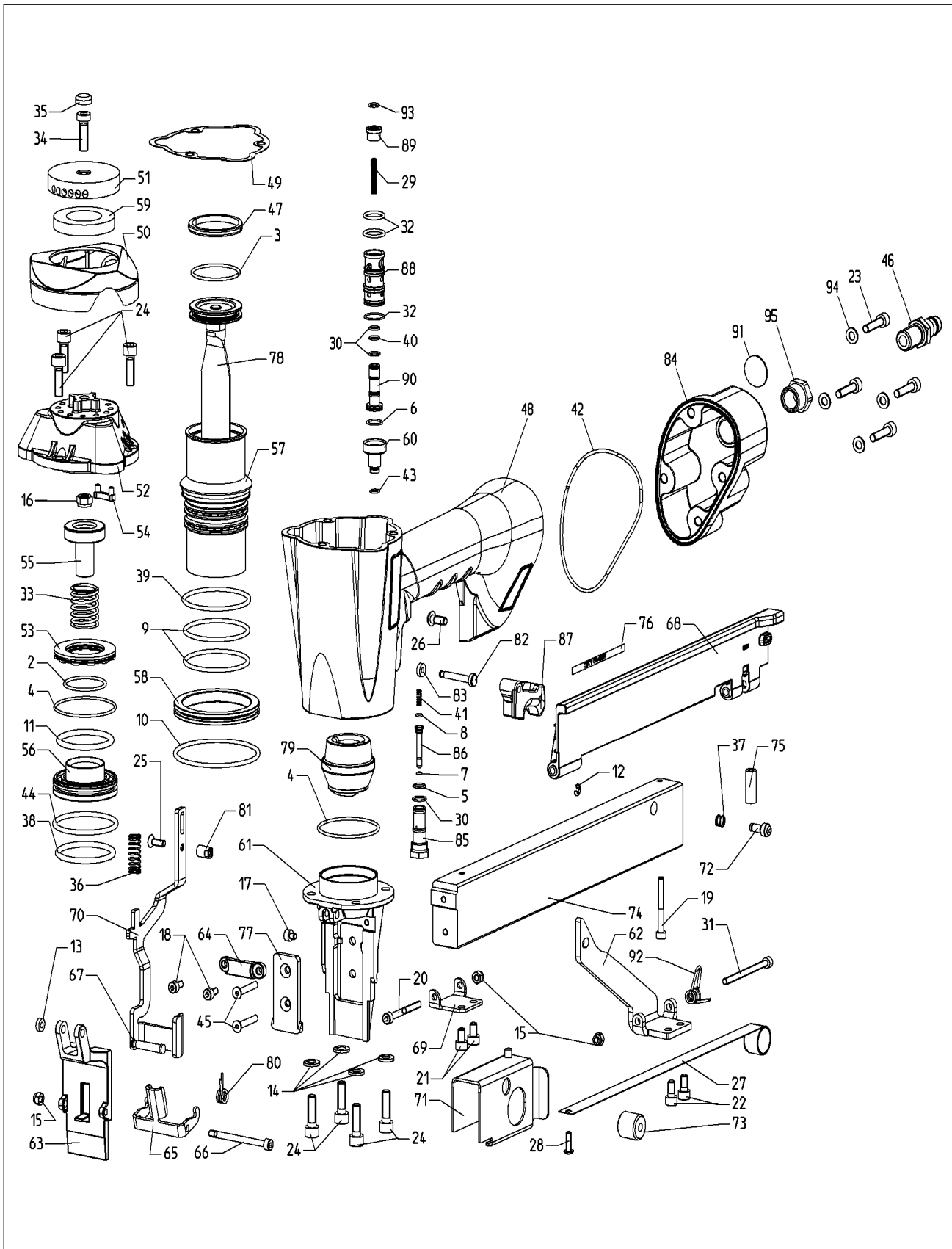

2	O-Ring	13300021	38	O-Ring	13303088	61	Kopfstück	14413119	80	Schenkelfeder	14408555
3	O-ring	13300024	39	O-ring	13303092		Nose housing			Leg spring	
4	Joint torique	13300028	40	Joint torique	13300007		Tête			R ressort à branches	
5	Aro torico	13300051		Aro torico			Testero			Muelle en pata	
6		13304007									
7		13300060	41	Druckfeder	13303110	62	Lasche	14413120	81	Hülse	14407743
8		13300065		Compression spring			Hook plate			Sleeve	
9		13300088		R ressort à pression			Plaquette d'ancrage			Douille	
10		13300114		Muelle de presión			Placa con ganchos			Adaptador	
11		13300133									
12	Sicherungsring	13300347	42	O-Ring	13303128	63	Kopfstückklappe	14413121	82	Ventilhebelstift	14407744
13	Circlip	13300355	43	O-ring	13303134		Nose housing door			Trigger valve stem	
	Clips		44	Joint torique	13303771		Clapet de la tête			Axe de levier de détente	
	Aro de seguridad			Aro torico			Puerta testero			Pasador valvula gatillo	
14	Federring	13300375	45	Senkschraube	13303939	64	Werkzeug Teil 1	14413122	83	Sicherungsring	14408556
	Spring washer			Countersunk screw			Front nose			Circlip	
	Clips			Vis creuse fraisée			Plaque frontale			Clips	
	Anillo elastico			Tornillo avellanado			Placa guia delantera			Aro de seguridad	
15	Sicherungsmutter	13300437	46	Stecknippel	14000244	65	Hebel	14413123	84	Schlagverstärker	14413541
16	Safety nut	13300439		Plug-in nipple			Lever			Booster	
	Ecrou de sûreté			Raccord enfichable			Levier			Amplificateur d'impact	
	Tornillo de seguridad			Manguito enchufable			Palanca			Amplifier d'impact	
17	Zylinderschraube	13301100	47	Kolbenring	14408883	66	Zylinderschraube	14413150	85	Ventilbuchse	14407761
18	Allan screw	13301102		Piston ring			Allan screw			Valve bush	
19	Vis cylindrique	13301111		Segment de piston			Vis cylindrique			Douille de soupape	
20	Tornillo allen	13301113		Aro del piston			Tornillo allen			Casquillo valvula	
21		13301115	48	Gehäuse	14408885	67	Achse	14413124	86	Schaltstift	14407762
22		13301116		Body			Pin			Valve pin	
23		13301121		Corps			Axe			Bouton de commande	
24		13303986		Cuerpo			Eje			Pasador valvula	
25	Senkschraube	13301273	49	Kappendichtung	14408886	68	Abdeckschiene, kompl	14413125	87	Ventilhebel, kompl.	14407946
	Countersunk screw			Cap seal			Cover, cpl			Trigger, compl	
	Vis creuse fraisée			Capuchon douille			Rail de couverture, cpl			Levier de détente	
	Tornillo avellanado			Cabeza de fijacion			Tapa cargador, cpl			Palanca valvula gatillo	
26	Linsenschraube	13301352	50	Kappenabdeckung	14408887	69	Winkel	14413127	88	Steuerhülse	14413986
	Lens head screw			Cover			Angle			Socket	
	Vis creuse fraisée			Cache			Angle			Douille	
	Tornillo cabeza de la lente			Tapa			Angulo			Casquillo	
27	Rollfeder	13301614	51	Luftleitdeckel	14408888	70	Auslösebügel	14413128	89	Steuerbuchse	14413759
	Roller spring			Air deflector			Safety yoke			Valve bushing	
	R ressort enroulé			Couvercle de déflecteur			Palpeur de sécurité			Douille de soupape	
	Muelle espiral			Tapa deflector de aire			Estribo de seguridad			Casquillo valvula	
28	Linsenschraube	13301774	52	Kappe	14408889	71	Vorschieber	14413129	90	Steuerkolben	14413758
	Lens head screw			Cap			Pusher			Piston	
	Vis creuse fraisée			Capuchon			Chariot			Piston	
	Tornillo cabeza de la lente			Cabeza			Empujador			Pistón	
29	Druckfeder	13301775	53	Kappenscheibe	14408890	72	Vorschieberarretierung	14413130	91	Aufkleber Öl	14408596
	Compression spring			Cap disc			Pusher stop			Oil label	
	R ressort à pression			Rondelle du capuchon			Bouton d'arrêt pour chariot			Huile Étiquette	
	Muelle de presión			Arandela de cabeza			Boton parada empujador			Acetite Etiqueta	
30	O-Ring	13302647	54	Stopfen	14408898	73	Rollfederhalter	14413131	92	Schenkelfeder	14404611
	O-ring			Post cap			Support for roller spring			Leg spring	
	Joint torique			Capuchon			Plaquette pour ressort enroulé			R ressort à branches	
	Aro torico			Capuchon			Soporte para muelle en rollo			Muelle en pata	
31	Zylinderschraube	13302942	55	Anschlagdämpfer	14409189	74	Klammerträger, kompl	14413540	93	O-Ring	13300057
	Allan screw			Piston stop			Staple carrier, cpl			O-ring	
	Vis cylindrique			Butée de piston			Support d'agrafes, cpl			Joint torique	
	Tornillo allen			Piston con tope			Cargador grapas, cpl			Aro torico	
32	O-Ring	13302993	56	Hauptventil	14408891	75	Buchse	14413133	94	Scheibe	13300467
	O-ring			Main valve			Bushing			Washer	
	Joint torique			Soupape principale			Douille			Rondelle	
	Aro torico			Valvula principal			Casquillo			Arandela	
33	Druckfeder	13302994	57	Zylinder	14408892	76	Aufkleber Magazin	14413134	95	Reduziernippel	14000067
	Compression spring			Cylinder			Magazine label			Reducing bush	
	R ressort à pression			Cylindre			Étiquette			Réducteur enfichable	
	Muelle de presión			Cilindro			Étiquette			Manguito reductor	
34	Zylinderschraube	13303014	58	Zylinderring	14408893	77	Werkzeug Teil 2	14413135			
	Allan screw			Cylinder spacer			Back nose				
	Vis cylindrique			Anneau de cylindre			Plaquette arrière				
	Tornillo allen			Espaciador del cilindro			Placa guia posterior				
35	Schraubenabdeckung	13303015	59	Schalldämpfer	14408894	78	Kolben, kompl	14413137			
	Screw Cover			Silencer			Piston, cpl				
	VisCache			Amortisseur de bruit			Piston, cpl				
	Tornillo Tapa			Silenciador			Piston, cpl				
36	Druckfeder	13303060	60	Zwischenhülse	14414629	79	Puffer	14413139			
37	Compression spring	13303063		Cylinder, intermediate valve			Bumper				
	R ressort à pression			Arbre intermédiaire			Amortisseur				
	Muelle de presión			Valvula intermedio cilindro			Amortiguador				

Serwis narzędzi

BeA[®]

BIZON



w Polsce:



BizeA Sp. z o.o.

Tomice, ul. Europejska 4

05-532 Baniocha k. Warszawy

www.bizea.com.pl



Kontakt z Działem Serwisu: serwis@bizea.com.pl

<https://www.bizea.com.pl/www/serwis.html>

Sprzedaż części zamiennych tel.: 22 244 17 26

Wysyłasz narzędzie do naszego Serwisu?

Skorzystaj z formularza na naszej stronie – kurier GLS odbierze paczkę i dostarczy do nas:

Pamiętaj o:

- bezpiecznym zapakowaniu przesyłki na czas transportu
- podaniu danych adresowych do odebrania narzędzia
- podaniu kontaktu do osoby, która może udzielić dodatkowych informacji
- załączeniu pełnego opisu usterki - dzięki temu będziemy mogli zwrócić uwagę na konkretne problemy

Informacje o narzędziach w serwisie tel.: 22 244 17 37

Zamówienia części zamiennych:

Polecamy schematy interaktywne do generowania zapytań / zamówień, wybieraj, wysyłaj szybko i wygodnie z naszej strony:

(dostępne dla zalogowanych użytkowników)

<https://www.bizea.com.pl/schematy/lista.php> :

