

Typ
Type

W15-788C

Art.-Nr. (12000660)

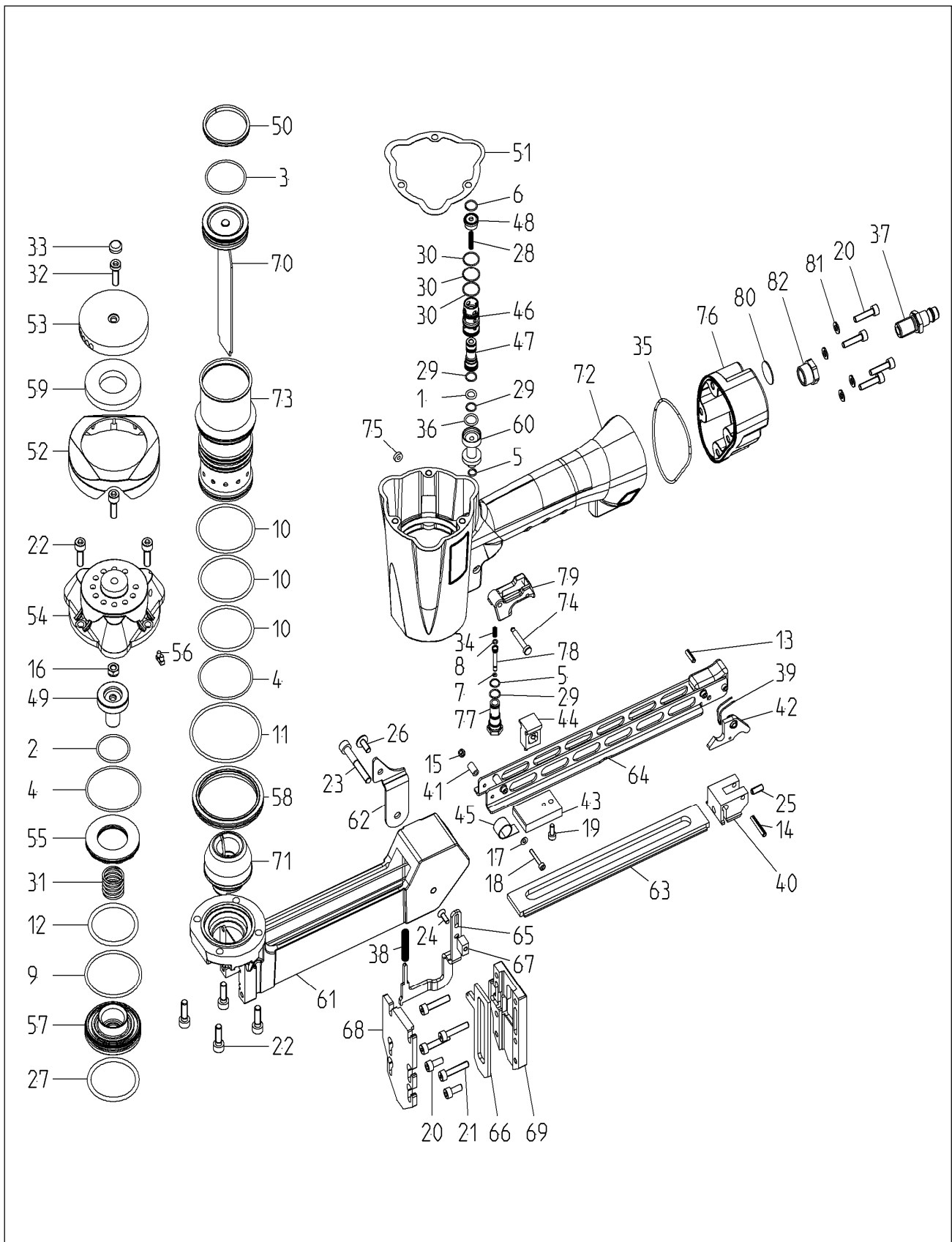

1	O-Ring	13300007	34	Druckfeder	13303110	51	Kappendichtung	14408576	67	Betätigungsblock	14415074
2	O-ring	13300021		Compression spring			Cap seal			Actuation block	
3	Joint torique	13300026		Ressort à pression			Capuchon douille			Bloc d'actionnement	
4	Aro torico	13300028		Muelle de presión			Cabeza de fijacion			Bloque de actuación	
5		13300051									
6		13300057	35	O-Ring	13303128	52	Kappenabdeckung	14408784	68	Werkzeug Teil 1	14414944
7		13300060	36	O-ring	13304007		Cover			Front nose	
8		13300065		Joint torique			Cache			Plaque frontale	
9		13300071		Aro torico			Tapa			Placa guia delantera	
10		13300091	37	Stecknippel	14000244	53	Luftleitdeckel	14408786	69	Werkzeug Teil 2	14414945
11		13300101		Plug-in nipple			Air deflector			Back nose	
12		13300135		Raccord enfichable			Couvercle de déflecteur			Plaque arrière	
				Manguito enchufable			Tapa deflectora de aire			Placa guia posterior	
13	Spannhülse	13300260	38	Druckfeder	13304030	54	Kappe	14408579	70	Kolben, kompl.	14415078
14	Split pin	13300264		Compression spring			Cap			Piston, cpl.	
	Douille fendue			Ressort à pression			Capuchon			Piston, cpl.	
	Pasador elastico			Muelle de presión			Cabeza			Piston, cpl.	
15	Sicherungsmutter	13300436	39	Schenkelfeder	14401756	55	Kappenscheibe	14408580	71	Puffer	14414950
16	Safety nut	13300439		Leg spring			Cap disc			Bumper	
	Ecrou de sûreté			Ressort à branches			Rondelle du capuchon			Amortisseur	
	Tornillo de seguridad			Muelle en pata			Arandela de cabeza			Amortiguador	
17	Scheibe	13300465	40	Anschlag	14401786	56	Stopfen	14408617	72	Gehäuse bearbeitet	14414946
	Washer			Stop			Post cap			Body machined	
	Rondelle			Butoir			Capuchon			Corps usinées	
	Arandela			Tope			Capuchon			Cuerpo acabado	
18	Zylinderschraube	13301096	41	Buchse	14401792	57	Hauptventil	14408581	73	Zylinder	14414947
19	Allan screw	13301103		Bushing			Main valve			Cylinder	
20	Vis cylindrique	13301121		Douille			Soupape principale			Cylindre	
21	Tornillo allen	13301123		Casquillo			Valvula principal			Cilindro	
22		13301137	42	Sperrklinke, kompl.	14401793	58	Zylinderring	14408583	74	Ventilhebelstift	14407744
23		13301142		Locking pawl, cpl.			Cylinder spacer			Trigger valve stem	
				Cliquet, cpl.			Anneau de cylindre			Axe de levier de détente	
				Trinquete de cierre, cpl.			Espaciador del cilindro			Pasador valvula gatillo	
24	Senkschraube	13301273	43	Schubstein	14406974	59	Schalldämpfer	14408584	75	Sicherungsring	14408556
	Countersunk screw			Feeder bar			Silencer			Circlip	
	Vis creuse fraisée			Chariot			Amortisseur de bruit			Clips	
	Tornillo avellanado			Empujador			Silenciador			Aro de seguridad	
25	Gewindestift	13301333	44	Führungsstein	14406973	60	Zwischenhülse	14414630	76	Schlagverstärker	14413541
	Grub screw			Guide block			Cylinder, intermediate valve			Booster	
	Douille fendue			Bloc de guidage			Arbre intermédiaire			Amplificateur d'impact	
	Tornillo de presion			Bloque guia			Valvula intermedio cilindro			Amplifier d'impact	
26	Linsenschraube	13301352	45	Rolfeder	14401895	61	Unterteil bearbeitet	14414952	77	Ventilbuchse	14407761
	Lens head screw			Roller spring			Magazine housing machined			Valve bush	
	Vis creuse fraisée			Ressort enroulé			Partie intérieure usinées			Douille de soupape	
	Tornillo cabeza de la lente			Muelle espiral			Cuerpo cargador acabado			Casquillo valvula	
27	O-Ring	13301758	46	Steuerhülse	14413986	62	Lasche	14414939	78	Schaltstift	14407762
	O-ring			Socket			Hook plate			Valve pin	
	Joint torique			Douille			Plaque d'ancrage			Bouton de commande	
	Aro torico			Casquillo			Placa con ganchos			Pasador valvula	
28	Druckfeder	13301775	47	Steuerkolben	14413758	63	Magazinboden	14414940	79	Ventilhebel, kompl.	14407946
	Compression spring			Piston			Magazine bottom			Trigger, compl.	
	Ressort à pression			Piston			Fond du chargeur			Levier de détente	
	Muelle de presión			Pistón			Parte inferior cargador			Palanca valvula gatillo	
29	O-Ring	13302647	48	Steuerbuchse	14413759	64	Abdeckschiene	14414943	80	Aufkleber Öl	14408596
30	O-ring	13302993		Valve bushing			Magazine cover			Oil label	
	Joint torique			Douille de soupape			Rail de couverture			Huile Étiquette	
	Aro torico			Casquillo valvula			Tapa cargador			Acete Etiqueta	
31	Druckfeder	13302994	49	Anschlagdämpfer	14409189	65	Auslösebügel	14414941	81	Scheibe	13300467
	Compression spring			Piston stop			Safety yoke			Washer	
	Ressort à pression			Butée de piston			Palpeur de sécurité			Rondelle	
	Muelle de presión			Piston con tope			Estribo de seguridad			Arandela	
32	Zylinderschraube	13303014	50	Kolbenring	14408618	66	Auslösezunge	14414942	82	Reduziernippel	14000067
	Allan screw			Piston ring			Work contacting element			Reducing bush	
	Vis cylindrique			Segment de piston			Declencheur integre			Réducteur enfichable	
	Tornillo allen			Aro del piston			Elemento de contacto			Manguito reductor	
33	Schraubenabdeckung	13303015									
	Screw Cover										
	VisCache										
	Tornillo Tapa										